

FILTER UNIT, mobile
Series UM 80 PN 4

Sheet No.
4015 E

1. Type index:

1.1. Filter unit: (ordering example)

UM. 80. 6VG. 10. B. P. -. P04. W06. L01. L05. O

1	2	3	4	5	6	7	8	9	10	11	12
---	---	---	---	---	---	---	---	---	----	----	----

- 1 series:
 UM = filter unit, mobile
- 2 nominal size: 80
- 3 filter-material and filter-fineness:
 10 VG = 10 $\mu\text{m}_{(e)}$, 6 VG = 7 $\mu\text{m}_{(e)}$, 3 VG = 5 $\mu\text{m}_{(e)}$, 1 VG = 4 $\mu\text{m}_{(e)}$ Interpor fleece (glass fibre)
 10 WVG = 10 $\mu\text{m}_{(e)}$, 3 WVG = 5 $\mu\text{m}_{(e)}$ Watersorp-filter element
- 4 resistance of pressure difference for filter element:
 10 = Δp 10 bar
- 5 filter element design:
 B = both sides open
- 6 sealing material:
 P = Nitrile (NBR)
 V = Viton (FPM), by agreement
- 7 filter element specification:
 - = standard
 VA = stainless steel
 IS06 = see sheet-no. 31601
- 8 pump unit:
 P04 = pump unit 04, NG 80.50 (standard-pump unit)

9 motor: (W = alternating current motor)

motor	electrical connection	volume flow	max. viscosity	doc.-no.
W06 ¹⁾	230V 50Hz	71,0 l/min	10-400 mm ² /s	43056-4
W09 ¹⁾	110V 60Hz	85,0 l/min	10-400 mm ² /s	43057-4

¹⁾ standard-motor

- 10 suction connection 1 1/2 " : (see sheet-no. 31961-4)
 L01 = hose-lance
 L02 = hose-fitting-lance
 L03 = hose-lance-protective filter
 L04 = hose-fitting-lance-protective filter
- 11 discharge connection 1 1/4 " : (see sheet-no. 31961-4)
 L05 = hose-lance
 L06 = hose-fitting-lance
- 12 clogging indicator at M1:
 - = without
 O = visual, 2,5 bar

1.2. Filter element: (ordering example)

01NR. 630. 6VG. 10. B. P. -

1	2	3	4	5	6	7
---	---	---	---	---	---	---

- 1 series:
 01NR. = standard-return-line filter element according to DIN 24550, T4
- 2 nominal size: 630
- 3 - 7 see type index-filter unit

Notice:

Only operate all motors listed on this data sheet in combination with the pump unit specified on the type plate under item 8.

Changes of measures and design are subject to alteration!

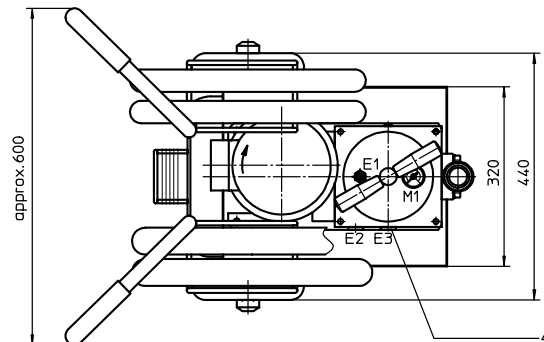
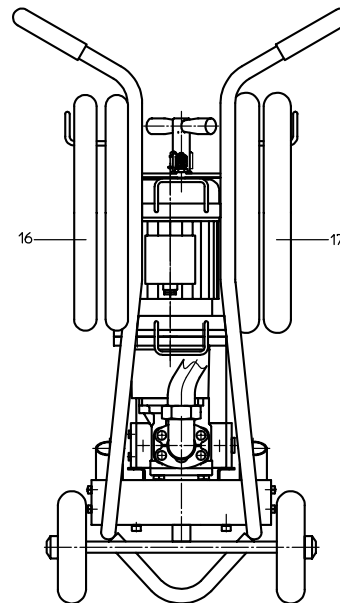
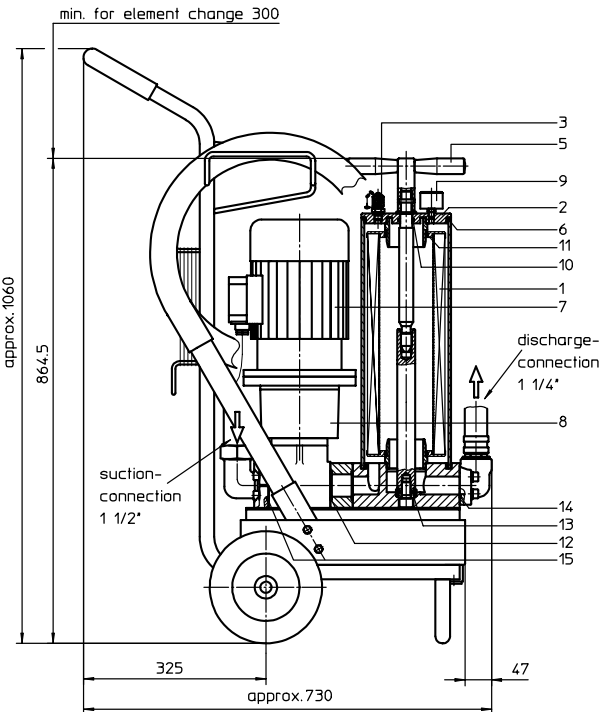

Assignment of connections and functions:

- E1: venting mini-measuring connection, MA.1.St see sheet-no.1650
 E2: drainage of filter, dirt side
 E3: drainage of filter, clean side
 M1: measure connection in the housing cover, dirt side

2. Spare parts:

item	designation	qty.	dimension	article-no.
1	filter element	1	01NR. 630	
2	housing cover	1	30600-3	315492
3	mini-measuring connection	1	MA.1.ST	305453
4	screw plug	2	G ½	304678
5	straining screw	1	30595-3	316312
6	O-ring	1	140 x 6	315392 (NBR)
7	electric motor	1	according to type index	
8	pump unit P04	1	NG 80.50	317139
9	clogging indicator (series)	1	visual Ø 40	315452
10	O-ring	1	22 x 3	304387 (NBR)
11	O-ring	2	70 x 4	306253 (NBR)
12	O-ring	2	45 x 3	304991 (NBR)
13	O-ring	1	18 x 3	304359 (NBR)
14	O-ring	1	37.69 x 3.53	304353 (NBR)
15	O-ring	1	47.22 x 3.53	305078 (NBR)
16	suction hose 1 ½ "	1	according to type index	
17	discharge hose 1 ¼ "	1	according to type index	

3. Designation:

The mobile filter unit is intended for oil maintenance on hydraulic systems.

The area of application comprises:

- secondary flow filtration in addition to the existing operating filter
- secondary flow filtration without the action of the operating filter
- filtration when filling the oil reservoir.

The filter unit must not be used to pump contaminated hydraulic fluids and is therefore designed without a switchover fitting to bypass the filter. The compact structural design on a base plate without pipe satisfies the prerequisites for small dimensions and high reliability. The transporting trolley makes it possible to move close up to confined locations with difficult access, and to fix the accessories (such as hoses and the connection cable) in a safe and reliable manner.

Oil flowing out of the suction and/or discharge hose or the outflow openings is collected by the filter unit's oil trough, without causing any environmental damage. The suction hose DN 40 and the discharge hose DN 32 are approximately 2700 mm long inclusive of the lance.

The device is equipped with a gear pump driven by an E-motor. The flow conveyed by the geared pump is fed over a filter element to DIN 24550, T4, nominal size 630.

Depending on the customer's wishes, the filter fineness is either 4, 5, 7 or 10 $\mu\text{m}_{(c)}$. The contamination level of the filter element can be read off from a pressure display in the cover of the filter.

At a pressure >2,5 bar (red area of the scale field), the filter element is contaminated and it must be replaced with a new filter element.

The filter element can be changed without tools. After removing the straining screw and taking off the housing cover, the filter element is accessible and it can be exchanged. The filter elements are supplied complete with seals. Since it is not possible to clean the elements, the user must always keep an adequate supply of spare elements in stock.

To protect against overpressure, the filter unit is fitted with a safety valve. Pressure setting about 4 bar.

The E-motor is made safe with a motor-protection-switch against overloading. At a working pressure > 4 bar, the motor-protection-switch cuts the E-motor out.

The line, venting and draining connections are identified according to their function. Drainage is necessary when cleaning the filter unit in connection with the change of filter element, and when changing the fluid medium.

4. Technical data:

filter-fineness: 4, 5, 7 or 10 $\mu\text{m}_{(c)}$
oil temperature: -5 bis +60°C
weight: approx. 73 kg
operating medium: hydraulic oil based on mineral oil from 10 mm²/s,
other media on request

Classified under the Pressure Vessel Directive 97/23/EC for mineral oil (fluid group 2), Article 3, Para. 3.

Classified under ATEX Directive 94/9/EC according to specific application (see questionnaire sheet-no. 34279-4).

5. Symbols:

filter unit without clogging indicator

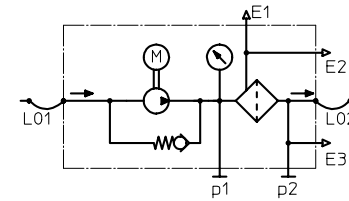

filter unit with visual clogging indicator

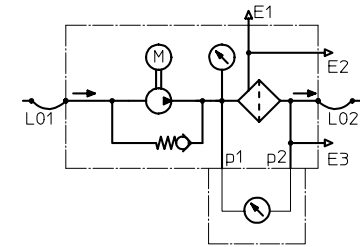

6. Test methods:

Filter elements are tested according to the following ISO standards:

ISO 2941	Verification of collapse/burst resistance
ISO 2942	Verification of fabrication integrity
ISO 2943	Verification of material compatibility with fluids
ISO 3723	Method for end load test
ISO 3724	Verification of flow fatigue characteristics
ISO 3968	Evaluation of pressure drop versus flow characteristics
ISO 16889	Multi-pass method for evaluating filtration performance